

Ficha Técnica  
Technical Data Sheet



Descripción	Description
<ul style="list-style-type: none"> <li>- Instalación en carril DIN, superficie o empotrado (65 x 65 mm).</li> <li>- Modelos con doble esfera de programación para dos circuitos independientes. Ej. Iluminación y riego en un jardín o arranque de una máquina y sus resistencias de calentamiento, ambas maniobras desde un mismo interruptor horario.</li> <li>- Las versiones con doble esfera disponen de dos contactos conmutados para programación: diaria-diaria o diaria-semanal.</li> <li>- Esfera frontal de sencilla programación mediante desplazamiento de caballetes.</li> <li>- Ventana transparente precintable para evitar manipulaciones no autorizadas.</li> <li>- Disponibles modelos con batería de reserva (≥ 100 h).</li> <li>- Conexiones Faston 4,8x0,5 mm para montaje empotrado en la puerta del armario eléctrico.</li> </ul>	<ul style="list-style-type: none"> <li>- Installation on DIN rail, surface or built in (65x65 mm).</li> <li>- Models with double programming sphere for two independent circuits. E.g. Lighting and irrigation in a garden or start up of a machine and its heating resistors, both operations from the same time switch.</li> <li>- Versions with double sphere have two changeover contacts for programming: daily-daily or daily-weekly.</li> <li>- Front sphere easy to program by movable trippers.</li> <li>- Sealable clear window to avoid unauthorised handling.</li> <li>- Models with backup battery available (≥ 100 h.).</li> <li>- Faston Connections 4.8 x 0.5 mm for built-in mounting in the electrical cabinet door.</li> </ul>

Aplicaciones	Area of application
Iluminación y riego en un jardín o arranque de una máquina y sus resistencias de calentamiento, ambas maniobras desde un mismo interruptor horario.	Lighting and irrigation in a garden or start up of a machine and its heating resistors, both operations from the same time switch.

Modelos Models	D	QRD	QRD 2x10	QRS	QRDD	QRSD
	diario sin reserva	diario con reserva de marcha	diario con reserva de marcha	semanal con reserva de marcha	diario -diario con reserva de marcha	diario-semanal con reserva de marcha
	daily without power reserve	daily with power reserve	daily with power reserve	weekly with power reserve	daily-daily with power reserve	daily-weekly with power reserve
Características técnicas Technical data						
Alimentación Power supply	230 Vac ± 10 %					
Frecuencia nominal Nominal frequency	50-60 Hz					
Consumo propio Power consumption	1 VA (0,9 W)					
	1 VA (0.9 W)					
Reserva de marcha Power reserve	sin reserva without reserve	100 h				
Precisión de marcha Operating accuracy	± 1 s / 24 h @23 °C					
Tipo de contacto Type of contact	Conmutado Changeover					
Poder de ruptura Switching capacity	16(4) A / 250 V ac					
Clase de protección Protection class	Clase II en condiciones correctas de montaje Class II in correct mounting conditions					
Grado de protección Degree of protection	IP20 según EN 60529 IP20 according to EN 60529					
Situación de contaminación Pollution degree	2					
Tipo de acción Action type	1B, 1T, 1U, 1R	1B, 1T, 1U, 1S				
Tipo de esfera Dial type	96 caballetes 96 pins		84 caballetes 84 pins		96-48 caballetes 96 - 48 pins	84-48 caballetes 84-48 pins
Tiempo mínimo de maniobra Minimum switching time	15 min		2 h		15 min- 30 min	30 min-2h
Precisión de la maniobra Setting accuracy	± 5 min		± 30 min		± 5 min	± 5 min ± 30 min
Tensión de impulso asignada Rated impulse voltage	2,5 kV 2.5 kV					
Temperatura para ensayo de la bola Ball pressure test temperature	85 °C (21.2.5) ; 105 °C (21.2.6)					
Montaje del equipo Method of mounting control	Montaje superficie / carril DIN / trascuadro Installation on DIN rail, surface or built-in					
Conexión Connection	Conexiones FASTON 4,8 x 0,5 mm borne de tornillo (M3) Faston Connections 4.8x0.5 mm screw terminal (M3)					
Sección de conductor Wire cross section	4 mm²					

# CRONO

DT05AAFT001 - 03\_03/2021

Par máximo de apriete de tornillos <i>Maximum torque for the screws</i>	0,5 Nm					
Tapa precintable <i>Sealable cover</i>	Sí Yes					
Temperatura de funcionamiento <i>Operating temperature</i>	-10°C a 50°C -10°C to 50°C					
Temperatura de transporte y almacenamiento <i>Transportation and storage temperature</i>	-20°C a 60°C -20°C to 60°C					
Peso neto <i>Net weight</i>	186 g	190 g	194 g	190 g	194 g	194 g

## Cargas máximas recomendadas Maximum recommended load

	Incandescentes <i>Incandescents</i>	Fluorescentes <i>Fluorescent</i>	Halógenas baja tensión (12 V c.a.) <i>Low voltage halogen (12 V AC)</i>	Halógenas (230 Vc.a.) <i>Halogen (230 V AC)</i>	Lámparas bajo consumo <i>Low consumption lamps</i>	Downlights <i>Downlights</i>	LED
							<b>LED</b>
	1000W	----	1000 VA	1000 W	----	----	----

## Conexión Wiring diagram

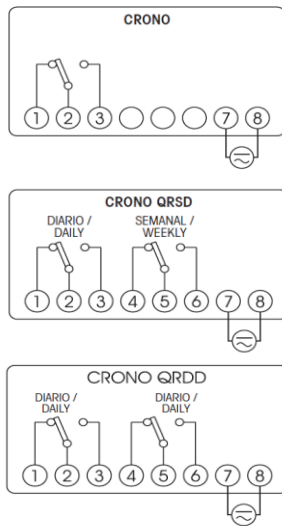

## Dimensiones exteriores Overall dimensions

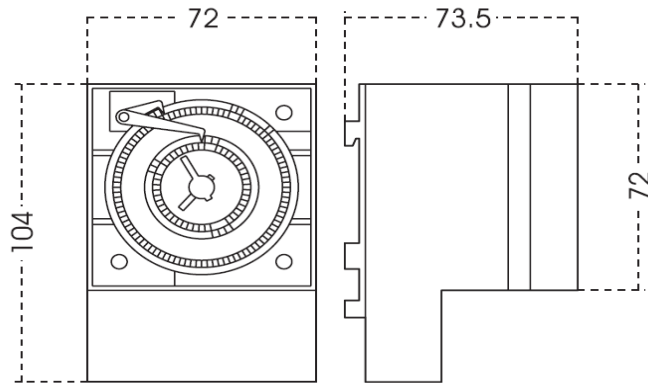

## Accesorios Accessories available

Código Code:	Código Code:	Código Code:

Código Code	D	QRD	QRD 2x10	QRS	QRDD	QRSD
230 V ac	OB050523	OB050623	OB051923	OB051023	OB050823	OB051223
120 V ac	OB050529	OB050629		OB051029	OB050829	OB051229
48 V ac/dc	OB050552	OB050652		OB051052	OB050852	OB051252
24 V ac/dc	OB050562	OB050662		OB051062	OB050862	OB051262
12 V ac/dc	OB050572	OB050672		OB051072	OB050872	OB051272

## Marcado Approvals and marking



## Directivas de referencia Reference Directives

2014/30/EU (EMC); 2014/35/EU (LVD); 2011/65/EU (RoHS)

## Normas de referencia Reference standards

EN 60730-1; EN 60730-2-7; EN IEC 63000

DT05AAFT001 - 03\_03/2021